

USN

--	--	--	--	--	--	--	--	--	--

10ME62

Sixth Semester B.E. Degree Examination, Feb./Mar.2022
Design of Machine Elements – II

Time: 3 hrs.

Max. Marks:100

Note: Answer FIVE full questions, selecting at least TWO questions from each part.

PART – A

- 1 a. List out the main differences between the straight and curved beam. Also sketch the stress distribution pattern in a curved beam. (05 Marks)
- b. For following T section shown in Fig. Q1 (b), determine the maximum stresses for inner and outer fibre of the member.

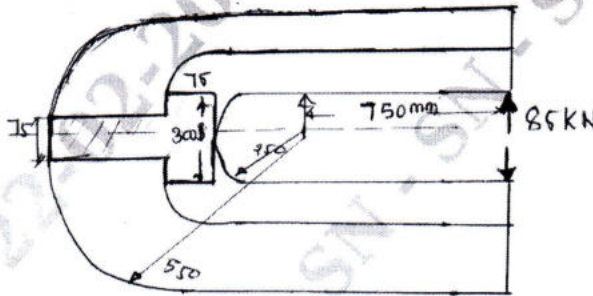

Fig. Q1 (b) (07 Marks)

- c. A high pressure cylinder consists of a steel tube with inner and outer diameters of 120 mm and 160 mm respectively. It is jacketed by an outer diameter of 200 mm. The tubes are assembled by a shrinking process in such a way that maximum principal stresses induced is 36.45 N/mm^2 . The shrink fit assembly is further subjected to an internal fluid pressure of 60 MPa determine,
 - (i) Shrinkage pressure. (ii) Resultant tangential and radial stresses. (08 Marks)
- 2 a. A belt is required to transmit 18.5 kW from a pulley of 1.2 m diameter running at 250 rpm to another pulley which run at 500 rpm. The distance between the centers of pulley is 2.7 m. The following data refer to an open belt drive $\mu = 0.25$, safe working stress for leather is 1.75 N/mm^2 . Thickness of belt = 10 mm. Determine the width and length of belt taking centrifugal tension into account. Also find the initial tension in the belt and absolute power that can be transmitted by this belt and the speed at which this can be transmitted. (10 Marks)
- b. Select a wire rope to lift a load of 10 kN through a height of 600 m from a mine. The weight of bucket is 2.5 kN. The load should attain a maximum speed of 50 m/min in 2 seconds. (10 Marks)
- 3 a. Derive an expression for the stress induced in a helical spring, with notations. (05 Marks)
- b. A spring controlled lever is shown in Fig. Q3 (b), the spring is to be inserted with an initial compression to produce a force equal to 125 N between the right end of lever and stop. When the maximum force at 'A' reaches a value of 200 N the end of the lever moves downward by 25 mm. Assume the spring index as 8, find (i) Spring rate (ii) Size of wire (iii) Outside dia of spring (iv) Number of active coils (v) Free length (vi) Pitch.

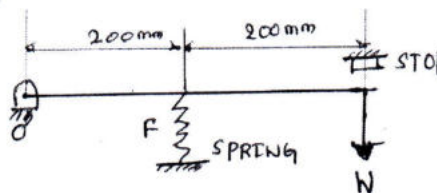

Fig. Q3 (b)

(15 Marks)

Important Note : 1. On completing your answers, compulsorily draw diagonal cross lines on the remaining blank pages.
2. Any revealing of identification, appeal to evaluator and /or equations written eg, 42+8 = 50, will be treated as malpractice.

- 4 Design a pair of spur gears to transmit a power of 18 kW from a shaft running at 1000 rpm to a parallel shaft to be run at 250 rpm maintaining a distance of 160 mm between the shaft centres. Suggest suitable surface hardness for the gear pair. (20 Marks)

PART - B

- 5 a. A pair of bevel gear transmitting 7.5 kW at 300 rpm of pinion. The pressure angle is 20° . The pitch diameter of pinion and gear at their large ends are 150 mm and 200 mm respectively. The face width of the gears is 40 mm. Determine the components of the resultant gear teeth force and draw a free body diagram of forces acting on the pinion and the gear. (10 Marks)
- b. A two teeth right hand worm transmits 2 kW at 1500 rpm to a 36 teeth wheel. The module of the wheel is 5 mm and the pitch diameter of the worm is 60 mm. The normal pressure angle is $14\frac{1}{2}^\circ$. The co-efficient of friction is found to be 0.06.
- Find the center distance the lead and lead angle.
 - Determine the forces
 - Determine the efficiency of the drive. (10 Marks)
- 6 a. A 25 kW at 3000 rpm is to be transmitted by a multiple friction clutch. The plates have friction surfaces of steel and phosphor bronze alternatively and run in oil. Design the clutch for 25% over load. (10 Marks)
- b. The torque absorbed in the band brake shown in Fig. Q6 (b) is $400 \times 10^3 \text{ N}\cdot\text{mm}$. Design the band and lever, taking $\mu = 0.27$ and diameter of drum as 400 mm. The allowable stress in band may be taken as 70 N/mm^2 .

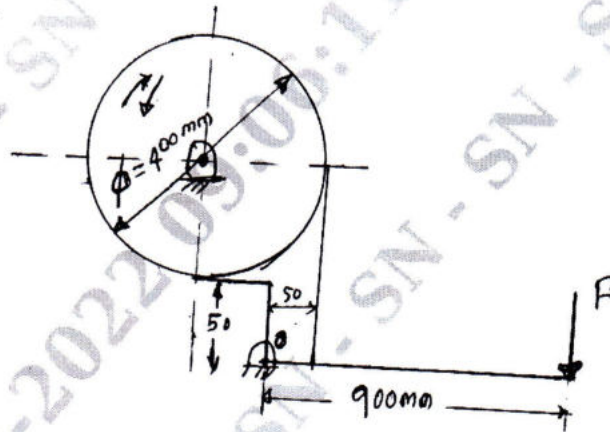

Fig. Q6 (b)

(10 Marks)

- 7 a. Derive Petroff's equation. (06 Marks)
- b. A 75 mm diameter full journal bearing supports a radial load of 3500 N. The bearing is 75 mm long and the shaft operates at 400 rpm. Assume a permissible minimum film thickness of 0.02 mm and a normal running fit for the bearing bore. Use Raimondi and Boyd curves determine,
- Absolute viscosity of the oil,
 - Co-efficient of friction
 - Heat generated
 - Amount of oil pumped through bearing.
 - Amount of end leakage.
 - Temperature rise of the oil flowing through the bearing. (14 Marks)

- 8 a. The following data is given for the piston of a four stroke diesel engine, cylinder bore = 100 mm, material = Grey cast iron, Allowable stress = 90 N/mm^2 , Allowable radial pressure = 0.035 MPa , Thickness of piston head = 16 mm, Number of piston rings = 4.

Calculate:

- (i) Radial width of piston ring.
- (ii) Axial thickness.
- (iii) Gap between free ends of the piston ring before assembly.
- (iv) Gap between the free ends of the piston ring after assembly.
- (v) Width of top band
- (vi) Width of ring grooves.
- (vii) Thickness barrel at open.

(10 Marks)

- b. The following data is given for the piston of a four stroke diesel engine : cylinder bore = 100 mm, Maximum gas pressure = 5 MPa, Bearing pressure = 25 MPa, length of piston pin = $0.45 D$, Mean diameter of piston bars = $1.4 \times$ outer diameter of piston pin.

Allowable bending stress for piston pin = 140 N/mm^2

- Calculate :
- (i) Outer diameter of piston pin
 - (ii) Inner diameter of piston pin
 - (iii) Mean diameter of piston boss
 - (iv) Check the design for bending stress.

(10 Marks)
